



20
23

Guidlines for inspection and servicing
Couplings



General information

General information

The components used to couple vehicles and trailers are exposed to very high stress, even during normal use. Regular service and maintenance is a prerequisite if the coupling is to function well for the duration of its service life. Clean and lubricate the coupling every week.

The length of the service interval depends on the type of trailer, loads, road and climatic conditions, etc. The service should ideally be carried out in conjunction with other inspection of the vehicle, e.g. every 60,000 or 90,000 km.

If daily inspection or safety checks show that any of the wear limits have been exceeded or that the function of the product has been impaired, servicing must be carried out immediately.

If any of the product's wear limits have been exceeded, this is an indication that other parts also require servicing.

Check that all type plates and warning/information labels are legible and have not been painted over, washed off or otherwise damaged. Illegible labels must be replaced and can be ordered from VBG Truck Equipment.

If the coupling is damaged as a result of jackknifing, off-road driving or reversing, the vehicle must be stopped and the coupling replaced.

NB! All coupling equipment must be depressurised and de-energised before servicing is carried out. This means that you must disconnect the air supply and power to actuator-assisted couplings.

Always follow VBGs instructions and the vehicle manufacturer's bodybuilding instructions.

Guidelines for inspection and servicing Couplings 2023

© VBG GROUP TRUCK EQUIPMENT AB

Version e, 12/04/2023

The content of this publication may not be reproduced either in full or in part without the prior approval of VBG GROUP TRUCK EQUIPMENT AB.

This prohibition is applicable for all forms of reproductions in all types of media, including electronic media.

Explanation of symbols



Warning!

Never put your fingers into the coupling mouth as they may be crushed. An open coupling always involves a risk of crushing due to the powerful springs that constitute the coupling's closing function.



Severity

3 = STOP to ensure future use.

2 = Rectify as soon as possible, within four weeks.

1 = Rectify when able or during next service. Within no more than one year.



Contents

General information on couplings	4
Couplings with V and Dc values.	10
Couplings with only D value.....	26
Mechanism.....	28
Air-assisted mechanisms	34
PA unit.....	36
Control kit for AM coupling.....	38

Checkpoint	Symptom	Fault
<p>Complete coupling.</p> 	<p>Possible fault:</p> <ul style="list-style-type: none"> • Broken signal pin. • Loose mechanism, actuator bracket. • Deformed coupling mouth, handle, bracket, etc. • The coupling is askew and bent. • The coupling turns when there is no drawbar connected. • The coupling bolt does not engage. The signal pin jams. • The coupling rattles. • The trailer/centre-axle trailer jolts, "winds". • The coupling bolt is not triggered during connection. 	<p>Possible fault:</p> <ul style="list-style-type: none"> • The signal pin does not indicate the correct position. • Loose mechanism bolts. • Rear-end collision actuator brackets, handles, etc. • Cracked, deformed coupling mouth. • Bent horizontal bolt. • Loose drawbeam sleeve bolts. • Worn rubber elements. • The castellated nut's protective cover is missing. • The castellated nut's locking device is incorrectly fitted/damaged/missing. • The coupling bolt does not assume a locked and secure position during connection. • The coupling bolt/bushings is/are worn out. • The locking pin jams. • The mechanism is worn out. • The wear plates are worn out. • Loose coupling mouth. • Loose handle.
<p>Complete coupling.</p>	<p>May be noise or play during use of the coupling. Connection and disconnection does not work 100%.</p>	<p>Loose bolted joints such as those between the drawbeam/drawbeam sleeve, mechanism/coupling jaw, coupling mouth/jaw, wear plate/coupling mouth, mechanism/mechanism cover and pneumatic actuator bracket/mechanism.</p>
<p>Complete coupling.</p>	<p>The coupling is bent to the side, up or down. The coupling mouth is bent, signs of jackknifing, etc.</p>	<p>Deformation of horizontal bolt/coupling jaw or other load-carrying part.</p>

Inspection method	Requirements, wear limits, etc.	 Instructions for rectification
<ul style="list-style-type: none"> • Visually check, take simple readings and operate coupling. • Inspect function, attachment, damage, wear. • Attachment also applies to coupling parts such as the lock mechanism's attachment to the coupling jaw. • Measurements are taken to determine wear to, among other things, the bolt and bushings. • Functional check of the coupling's control and locking device by moving the coupling into the open position and into the locked position using a drawbar eye and by pulling the coupling bolt up using tools. • First and second locking are included in the locking device. • Any damage to the horizontal bolt caused by worn bushings in the drawbeam sleeve or cavities after variation of current between the vehicle and trailer must be measured. • Check that the coupling can rotate in its attachment to the drawbeam. 	<p>Information on the coupling's labels, signs' location, performance, spare parts, driver manuals, assembly instructions, space requirements, etc. can be found on VBG's website.</p> <p>Information on important daily inspection/ maintenance that can be performed without workshop equipment and the coupling's function is included in the "Driver's Manual" available on the VBG website.</p> <p>Examples of important requirements.</p> <ul style="list-style-type: none"> • If the coupling is damaged due to e.g. jackknifing, off-road driving or reversing, the vehicle must be stopped and the coupling replaced. • The coupling equipment must be equipped with warning and information labels. • Welding, drilling or otherwise modifying the coupling is not permitted. • Wear limits, see specific coupling model. • The coupling must be able to rotate in its attachment $\pm 25^\circ$, torque 100–1,000 Nm. • When the coupling is in the locked position, the signal pin must be level with the mechanism housing; if the coupling is remote-controlled, there must also be a separate indicator that shows a green coupling symbol when the coupling is closed and locked. • When the coupling is open, the signal pin must protrude approx. 10 mm out of the mechanism; if the coupling is remote-controlled, there must also be a separate indicator that shows red coupling symbol. • • • When the coupling is in the locked position, it must be possible to push the coupling bolt up 0–5 mm. 	<p>① ② ③</p>
<p>Visual check of the attachment, damage and discolouration of rust-coloured water near the joint surfaces. Torque-tighten the bolts if you suspect low tension.</p>	<p>No movement is permitted and there should be no rotation during test-tightening to the prescribed tightening torque; see installation instructions for each coupling model.</p>	<p>②</p> <p>In the event of any movement or too low a tightening torque, the parts should be dismantled and checked. If there is any visible damage, these parts must be replaced. When the components have been dismantled, they must be re-tightened after driving 2,500 km.</p>
<p>Visual check of centring around the coupling's centreline in vehicle direction and functional test. Dismantling and measuring in the event of jackknifing damage.</p>	<p>No deformations permitted. Deviations of more than 2 mm from the original position are defined as deformations. In the event of deviation of 2 mm or more, driving with a trailer is not permitted. However, max. 0.5 mm for the horizontal bolt; see checkpoint "Coupling jaw for fixed drawbar".</p>	<p>③</p> <p>Load-bearing components with deformations measuring 2 mm or more from their original position must be replaced and driving stopped.</p>

General information on couplings

Checkpoint	Symptom	Fault
Complete coupling.	Narrow rust-coloured streaks, cracks in the paint/paint is peeling.	Cracks.
The coupling bolt's wear area.	<p>The coupling bolt moves up and down slightly when the traction vehicle pushes and pulls at the drawbar.</p> <p>The coupling bolt's wear/marks from the eye are below the coupling bolt's biggest diameter.</p> <p>The coupling bolt's wear/marks from the eye are below and above the coupling bolt's biggest diameter.</p> <p>Quick wear, which leads to play between the vehicle and trailer; constant jolting between the vehicle and trailer may occur.</p>	The coupling bolt's wear/eye marks are incorrectly positioned on the coupling bolt (not centred over the "coupling bolt's wear surface for the eye") due to worn wear plate and/or incorrect drawbar height for coupling.

Inspection method

Requirements, wear limits, etc.



Instructions for rectification

To be checked visually, corners, radius transitions, holes, bolted joints, welded joints, etc. The surfaces must be dry and well cleaned.

No cracks are permitted.

③ Driving must be stopped immediately; cracked parts must always be replaced.

Observe any vertical movement of the coupling bolt when the vehicle pushes and pulls at the braked trailer.
Check the coupling bolt's wear pattern. Picture 1, green field in the middle displays the correct wear amount. Picture 2, red field indicates a drawbar eye that is too low due to a worn wear plate. Picture 3 shows a drawbar that is connected at the wrong height relative to the coupling, i.e. wear both above and below the coupling bolt's green field.

There must be no vertical movement of the coupling bolt when the vehicle is pulling and pushing at the braked trailer. There should be no wear outside of what is indicated in coupling bolt picture 1 or the minimum diameters specified in the table below.



① If the wear on the bolt is too low or the wear plate's minimum height is indicated, it must be replaced. When the wear to the eye for the bolt is too great, the drawbar's balancing force will be reduced; the eye must rest firmly in the coupling mouth.

① If the wear looks like it does on coupling bolt no. 3, the drawbar is at the incorrect height relative to the coupling, in which case its attachments should be rebuilt; the drawbar should be horizontal in the operating position.

② If the bolt is outside of the specified limits in terms of the smallest diameter, the mechanism must be replaced.

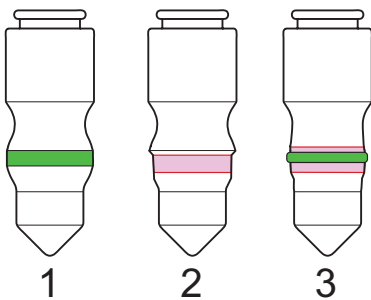

	1	2	A (mm)	B (mm)
	VBG 750V/795V/795VR		≥42,5	≥55,0
	VBG 760		≥44,8	≥55,0
	VBG 8500 ² /5190D/5200D		≥38,5	≥47,0
	VBG 8500-3 ¹		≥39,5	≥47,0
	VBG 8040/4140D		≥28,4	≥36,5
	VBG 575V/590VR		≥33,5	≥47,0

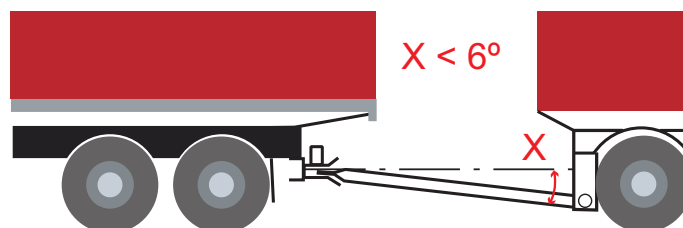





The drawbar closure should be less than 6°.

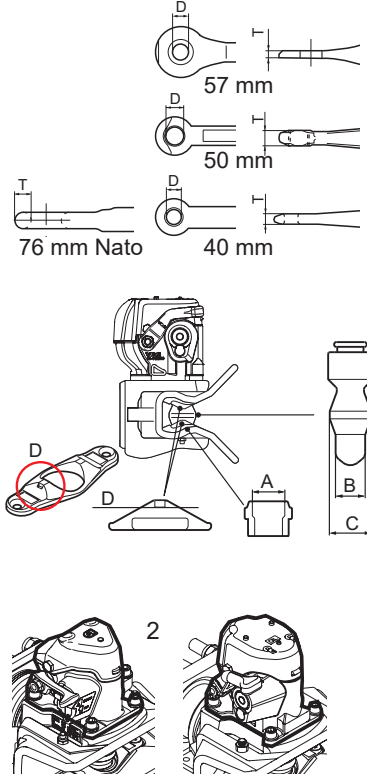



General information on couplings

Checkpoint	Symptom	Fault
The coupling bolt's wear area.	Quick wear, which leads to play between the vehicle and trailer; constant jolting between the vehicle and trailer may occur.	The coupling bolt wears out quickly. Significant total play between the vehicle and trailer because the eye's wear ring/bushing is worn and/or the coupling bolt and its bushings are worn.
The coupling bolt's wear area.	"Rattling" sound from the drawbar eye/coupling. Quick wear, which leads to play between the vehicle and trailer; constant jolting between the vehicle and trailer may occur.	Worn coupling bolt. Incorrectly balanced drawbar.
The coupling bolt's wear area.	The bolt appears to have corroded.	Small cavities on the bolt surface. Poor ground connection with the traction vehicle.

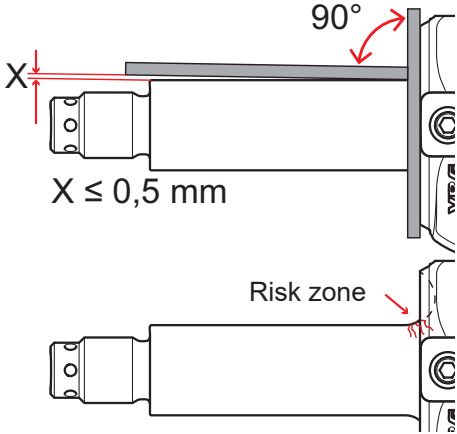
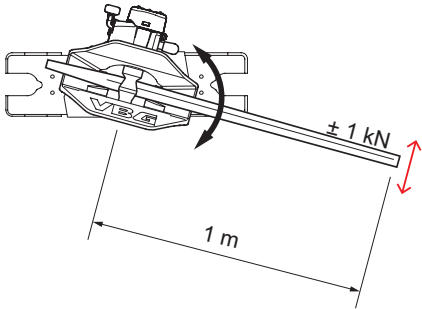



Inspection method	Requirements, wear limits, etc.	 Instructions for rectification																																																		
<p>Visually check the drawbar eye's wear ring/bushing and measure the diameter of the wear ring/bushing. Visually check the coupling bolt and the upper/lower jaw bushing and measure each diameter.</p>	<p>All measured diameters must be within the limits specified below.</p> <table border="1" data-bbox="624 344 992 539"> <thead> <tr> <th>Type</th> <th>≤ D (mm)</th> <th>≥ T (mm)</th> </tr> </thead> <tbody> <tr> <td>SS 57</td> <td>59,5</td> <td>19</td> </tr> <tr> <td>ISO 50</td> <td>52</td> <td>42,5</td> </tr> <tr> <td>DIN 40</td> <td>42</td> <td>28</td> </tr> <tr> <td>Nato 76</td> <td>-</td> <td>37</td> </tr> </tbody> </table>  <table border="1" data-bbox="576 1379 1458 1644"> <thead> <tr> <th></th> <th>A (mm)</th> <th>B (mm)</th> <th>C (mm)</th> <th>D (mm)</th> </tr> </thead> <tbody> <tr> <td>VBG 750/795/795VR</td> <td>≤ 45,7</td> <td>≥ 42,5</td> <td>≥ 55,0</td> <td>marking on wear plate</td> </tr> <tr> <td>VBG 760</td> <td>≤ 49,5</td> <td>≥ 44,8</td> <td>≥ 55,0</td> <td></td> </tr> <tr> <td>VBG 8500²/5190D/5200D</td> <td>≤ 41,3</td> <td>≥ 38,5</td> <td>≥ 47,0</td> <td></td> </tr> <tr> <td>VBG 8500-3¹</td> <td>≤ 42,3</td> <td>≥ 39,5</td> <td>≥ 47,0</td> <td></td> </tr> <tr> <td>VBG 8040/4140D</td> <td>≤ 31,5</td> <td>≥ 28,4</td> <td>≥ 36,5</td> <td></td> </tr> <tr> <td>VBG 575V/590VR</td> <td>≤ 36,5</td> <td>≥ 33,5</td> <td>≥ 47,0</td> <td>marking on wear plate</td> </tr> </tbody> </table>	Type	≤ D (mm)	≥ T (mm)	SS 57	59,5	19	ISO 50	52	42,5	DIN 40	42	28	Nato 76	-	37		A (mm)	B (mm)	C (mm)	D (mm)	VBG 750/795/795VR	≤ 45,7	≥ 42,5	≥ 55,0	marking on wear plate	VBG 760	≤ 49,5	≥ 44,8	≥ 55,0		VBG 8500 ² /5190D/5200D	≤ 41,3	≥ 38,5	≥ 47,0		VBG 8500-3 ¹	≤ 42,3	≥ 39,5	≥ 47,0		VBG 8040/4140D	≤ 31,5	≥ 28,4	≥ 36,5		VBG 575V/590VR	≤ 36,5	≥ 33,5	≥ 47,0	marking on wear plate	<p>② Replace components outside of the specified max./min. dimensions.</p>
Type	≤ D (mm)	≥ T (mm)																																																		
SS 57	59,5	19																																																		
ISO 50	52	42,5																																																		
DIN 40	42	28																																																		
Nato 76	-	37																																																		
	A (mm)	B (mm)	C (mm)	D (mm)																																																
VBG 750/795/795VR	≤ 45,7	≥ 42,5	≥ 55,0	marking on wear plate																																																
VBG 760	≤ 49,5	≥ 44,8	≥ 55,0																																																	
VBG 8500 ² /5190D/5200D	≤ 41,3	≥ 38,5	≥ 47,0																																																	
VBG 8500-3 ¹	≤ 42,3	≥ 39,5	≥ 47,0																																																	
VBG 8040/4140D	≤ 31,5	≥ 28,4	≥ 36,5																																																	
VBG 575V/590VR	≤ 36,5	≥ 33,5	≥ 47,0	marking on wear plate																																																
<p>Estimate the support load of a fixed drawbar or from an articulated drawbar.</p>	<p>Fixed drawbar: Support load 2–5 kN (200-500 kg)</p> <p>Articulated drawbar: Support load 100–500 N (10-50 kg)</p>	<p>① If necessary, the support load must be adjusted.</p>																																																		
<p>Measure any difference in voltage between the traction vehicle and trailer, which are only connected electrically if there is a full load. Measure between the drawbar eye and grounding point for the traction vehicle.</p>	<p>There must be no difference in voltage.</p>	<p>① Ensure that the ground connection is correct so that all return current goes via the electric cables.</p>																																																		

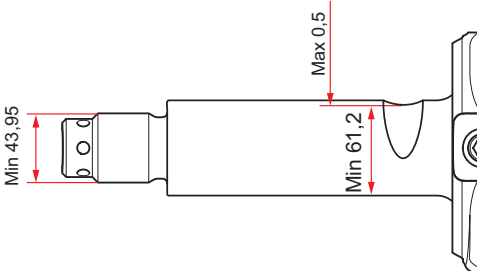
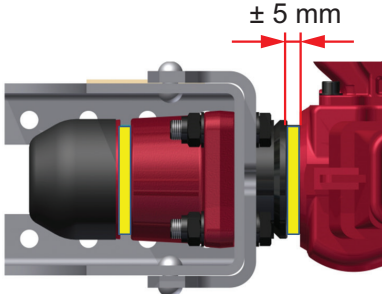
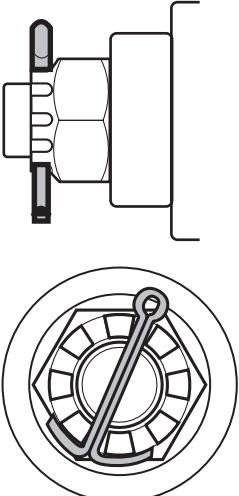

Checkpoint	Symptom	Fault
<p>Coupling jaw for fixed and/or articulated drawbars.</p> 	<p>Askew in the attachment, vertical and/or lateral deformation, damaged/broken coupling mouth. Damaged surrounding equipment such as endplates, beams and coupling mouth. Suspicion of reversing, off-road driving, jackknifing, etc. Other symptoms may include differences in the build-up of dust and residual rubber on the contact surfaces between rubber elements and the coupling jaw.</p>	<p>Bent horizontal bolt and/or cracks in the horizontal bolt.</p>
<p>Coupling jaw for fixed and/or articulated drawbars.</p> 	<p>Reduced comfort, more noise and more noticeable jolting during driving.</p>	<p>Coupling jaw stuck with rust or deformation. Cannot be rotated.</p>
<p>Coupling jaw for fixed and/or articulated drawbars.</p> 	<p>The coupling will rotate when no trailer is connected. Difficult to connect.</p>	<p>The coupling jaw rotates too easily.</p>



Inspection method	Requirements, wear limits, etc.	 Instructions for rectification
<p>Dismantle the coupling jaw. Measure the perpendicular alignment between the coupling jaw's circular part (the rubber element's contact surface) and the horizontal bolt, see picture. Visually check that the horizontal bolt does not have cracks in the radius transition against the rubber element's contact surface. Check other surrounding equipment such as endplates, drawbeam and underrun protection etc.</p>	<p>The horizontal bolt must be perpendicular to the coupling jaw's circular part for 0.5 mm of the horizontal bolt's length. No cracks are allowed.</p> 	<p>① ② ③</p> <p>③ If there are cracks, replace the coupling. In the event of deviation greater than 0.5 mm, replace the coupling.</p>
<p>Rotate the coupling by inserting a rod through the coupling mouth. Length 1 m, power 1 kN.</p> 	<p>The coupling should rotate at 1,000 Nm.</p>	<p>② If the coupling jaw is stuck, it must be removed from the drawbeam sleeve. Clean the horizontal bolt and the drawbeam sleeve. In the event of worn bearings, replace bushings including rubber elements.</p> <p>③ In the event of a damaged horizontal bolt, replace the coupling jaw. If the drawbeam sleeve is damaged, it must be replaced.</p>
<p>Visual check of rubber elements. Must not be easy to rotate by hand.</p>	<p>Minimum torque for rotation 100 Nm.</p>	<p>② In the event of worn bearings, replace bushings including rubber elements.</p>

Checkpoint	Symptom	Fault
<p>Coupling jaw for fixed and/or articulated drawbars.</p> 	<p>Major radial play between the coupling jaw and drawbeam sleeve, vertically and/or laterally. Reduced comfort, more noise during driving, increased wear to rubber elements.</p>	<p>The horizontal bolt's diameter is too small due to worn bushings and/or creeping-current damage caused by an undersized ground connection to the vehicle's battery.</p>
<p>Coupling jaw for fixed and/or articulated drawbars.</p> 	<p>Significant movement between the coupling jaw and drawbeam.</p>	<p>Significant movement/play longitudinally due to worn rubber elements.</p>
<p>Coupling jaw for fixed and/or articulated drawbars.</p> 	<p>Cotter bent/deformed due to rotation between the nut and coupling jaw. Detected during annual inspection.</p> 	<p>The castellated nut's cotter is defective.</p>

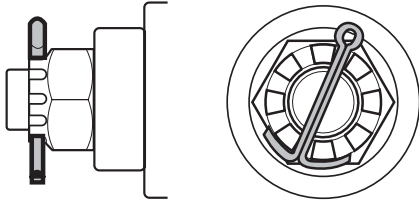
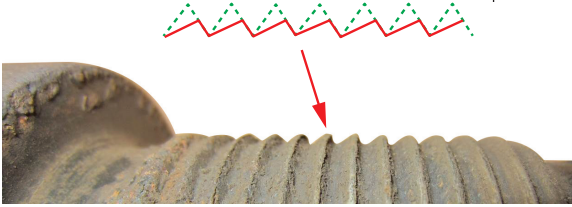

Inspection method	Requirements, wear limits, etc.	 Instructions for rectification
<p>Dismantle the coupling jaw. Visually inspect the threads and any wear and/or ring-shaped creeping-current damage to the horizontal bolt. Check the voltage difference between the trailer's drawbar eye and the traction vehicle's ground connection (-31). Measure only when the vehicle is connected electrically and with a full electrical load from the trailer. Now that the trailer has more devices that consume electricity, the earthing between the truck and the trailer is even more important. Insufficient earthing between truck and trailer will cause the return circuit to generate creeping current. Creeping currents can move from the trailer via the trailer coupling to the truck and damage components. Continuously check that earthing via the power plug is adequate. The return connection (earth cable) must always be dimensioned for maximum power consumption.</p>	<p>The thread flanks must be symmetrical, the thread's top diameter min. 43.95 mm. (M45x3 6g, top diameter = 44.577 - 44.952). The smallest permitted diameter along the horizontal bolt is 61.2 mm. Current leakage damage, max. depth 0.5 mm. There must be no difference in voltage; all differences in voltage may lead to corrosion/oxidation.</p> 	<p>① ② ③</p> <p>③ Clean the horizontal bolt and the drawbeam sleeve. In the event of a damaged horizontal bolt, replace the coupling jaw. Check that there is no damage to the drawbeam sleeve's contact surface for the bushings. Damaged drawbeam sleeve must be replaced.</p>
<p>Visually inspect the rubber elements to ensure that there are no chips, deformations or other indications of wear. Apply trailer brake, push and pull using the traction vehicle. Measure maximum and minimum distance between the coupling jaw and the washer for the rear rubber element.</p>	<p>The movement must not exceed ± 5 mm, i.e. total movement max. 10 mm.</p> 	<p>① In the event of significant movement ($\geq \pm 5$ mm), the rubber elements must be replaced including drawbeam sleeve bushings.</p>
<p>Visually inspect the fitted cotter. Correct locking.</p> 	<p>The castellated nut must be torque-tightened using torque 1,500–2,000 Nm. The cotter must be properly locked.</p>	<p>② Remove the bent/deformed cotter. Check that the castellated nut has the correct tightening torque and lock using a new cotter.</p>

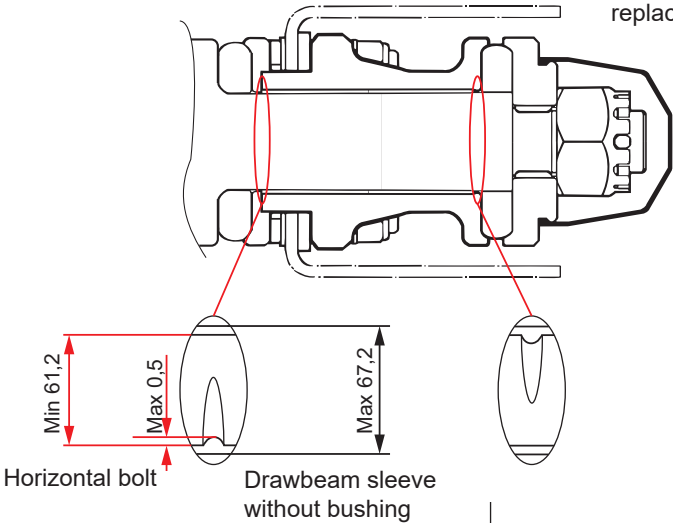
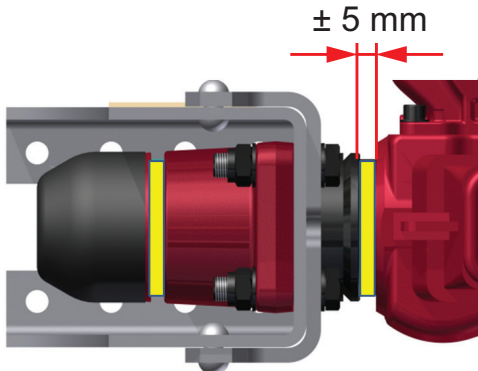

Checkpoint	Symptom	Fault
<p>Coupling jaw for fixed and/or articulated drawbars.</p> 	<p>The castellated nut does not have a tightening torque/the coupling jaw is loose. Detected during annual inspection.</p>	<p>Castellated nut cotter cut off/missing. The photo shows a cut-off cotter where parts still remain on the horizontal bolt.</p> 
<p>Attachment package Nut washer VR couplings.</p> 	<p>Cotter bent or cut off. The coupling rotates too easily. Jackknifing damage on endplates, beam, coupling, etc.</p>	<p>The VR couplings' nut washer under the castellated nut is bent. The coupling has been overloaded.</p>
<p>The drawbeam sleeve's M20 bolts.</p> 	<p>No rust residue around bolt head/nut or dust/dirt next to the bolt head or nut.</p>	<p>Bolt is loose or missing.</p>

<p style="text-align: center;">Inspection method</p>	<p style="text-align: center;">Requirements, wear limits, etc.</p>	<p style="text-align: center;">Instructions for rectification</p>
<p>Visually inspect the fitted cotter. Correct locking.</p> 	<p>The castellated nut should be tightened to a torque of 1,500–2,000 Nm. The cotter must be properly locked. If the castellated nut has come loose, the horizontal bolt's thread may become worn and its sides asymmetrical.</p> 	<p style="text-align: center;"> ①②③</p> <p>③ Dismantle the coupling jaw. Visually inspect the horizontal bolt's thread flanks. In the event of a damaged horizontal bolt, replace the coupling jaw.</p>
<p>Visually inspect the fitted cotter. If it is in any way not installed correctly or otherwise affected, it must be removed and the castellated nut fully loosened. Then check the flatness of the nut washer.</p> 	<p>The cotter must be intact and two of the castellated nut's ports must be in the centre of the cotter hole in the horizontal bolt. The nut washer should be completely flat.</p>	<p>③ Remove the coupling if the cotter is deformed or cut off. If the nut washer is not flat, the coupling must be replaced.</p>
<p>Visually check for any symptoms.</p>	<p>Torque-tighten to the specified torque, 370 Nm. There should be no movement between the nut and bolt.</p>	<p>② If any bolts are loose or missing, all four bolts must be replaced.</p>

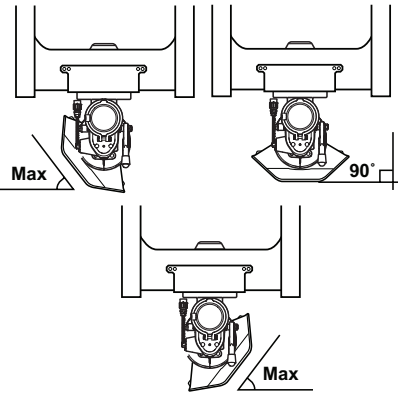
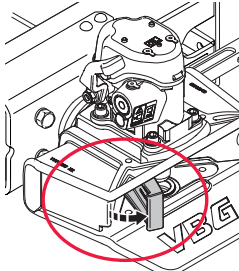
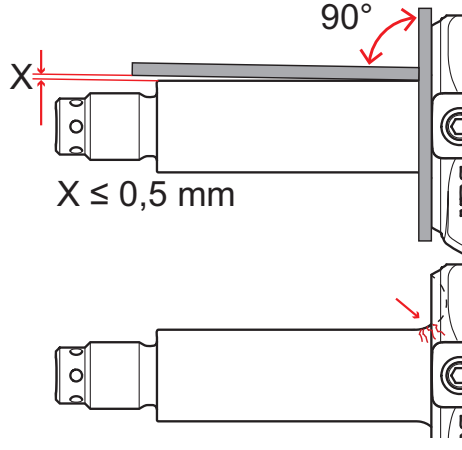

Checkpoint	Symptom	Fault
<p>Drawbeam sleeve.</p> 	<p>Major radial play between the coupling jaw and drawbeam sleeve, vertically and/or laterally. Reduced comfort, more noise during driving, increased wear to rubber elements.</p>	<p>Drawbeam sleeve bushings worn and/or the diameter of the sleeve too large due to driving with worn bushings.</p>
<p>Rubber elements.</p> 	<p>Significant movement between the coupling jaw and drawbeam.</p>	<p>Significant movement/play longitudinally due to worn rubber elements.</p>

Inspection method	Requirements, wear limits, etc.	 Instructions for rectification
<p>Remove the coupling jaw annually. Visually check the plastic bushings and for any indications of wear. Measure the diameter of both ends of the drawbeam sleeve. Measure the coupling jaw's diameter in the middle of the drawbeam sleeve. Measure the coupling jaw horizontal bolt's smallest diameter. During the annual removal of the coupling jaw, the drawbeam must be checked for any reversal deformations and cracking.</p>	<p>Compare the measured dimensions with the picture below. The smallest cross section of the horizontal bolt must never be less than 61.2 mm. The drawbeam sleeve's dimension must never exceed 67.2 mm. Maximum movement vertically and/or sideways may not exceed ± 5 mm measured from the coupling bolt. This movement is measured when the coupling jaw is correctly positioned in the longitudinal direction relative to the drawbeam sleeve and then again without rubber elements fitted.</p>  <p>Horizontal bolt Drawbeam sleeve without bushing</p>	<p>① ② ③</p> <p>② Remove coupling jaw from the drawbeam sleeve. Clean the horizontal bolt and the drawbeam sleeve. In the event of worn bushings, replace these including the rubber elements.</p> <p>③ In the event of a damaged horizontal bolt, replace the coupling jaw. If the drawbeam sleeve is damaged, it must be replaced.</p>
<p>Visually inspect the rubber elements. There should be no chips, deformations or other indications of wear. Apply trailer brake, push and pull using the traction vehicle. Measure maximum and minimum distance between the coupling jaw and the washer for the rear rubber element.</p>	<p>The movement must not exceed ± 5 mm, i.e. total movement max. 10 mm.</p>  <p>± 5 mm</p>	<p>① In the event of significant movement ($\geq \pm 5$ mm), the rubber elements must be replaced including drawbeam sleeve bushings.</p>

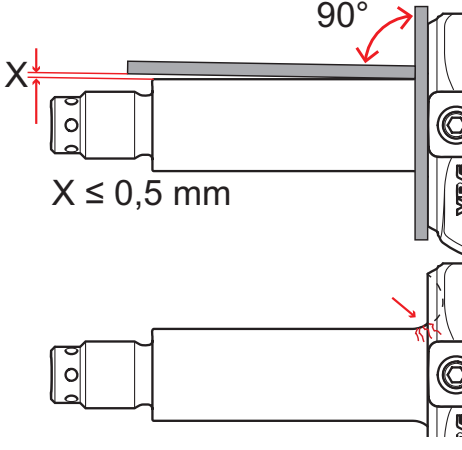

Checkpoint	Symptom	Fault
<p>Coupling mouth VBG 575V/590V, VBG 575V-2/590VR-2. VBG 575V-3/590VR-3.</p> 	<p>Reduced guidance. Noise while driving. Incorrect height of the drawbar eye's wear on the coupling bolt.</p>	<p>Deformed or broken coupling mouth, deformed or broken rubber element or guide arms due to overload during connection or potential jackknifing of the drawbar.</p>
<p>Coupling mouth VBG 795V/795V-2, VBG 795VR/795VR-2.</p> 	<p>Reduced guidance. Noise while driving. Incorrect height of the drawbar eye's wear on the coupling bolt.</p>	<p>Deformed or broken coupling mouth due to overload during connection or potential jackknifing of the drawbar.</p>

<p style="text-align: center;">Inspection method</p>	<p style="text-align: center;">Requirements, wear limits, etc.</p>	<p style="text-align: center;">Instructions for rectification</p>
<p>Check all functions of the variable coupling mouth, locking in the connected position straight ahead. Check in particular for any damage arising due to jackknifing, reversing, etc. The coupling can be opened when the coupling mouth is in its normal position or at a maximum angle to its outer positions.</p>  <p>Check guide arms and rubber elements. Check in particular for any damage arising due to jackknifing, reversing, etc.</p> 	<p>No deformations or cracks are permitted. All functions such as coupling mouth locking, recovery, guide arms, etc. must have full functionality. In the event of damage arising from jackknifing, the horizontal bolt must be carefully examined with respect to bending and any cracks.</p> 	<p style="text-align: center;"> ①②③</p> <ol style="list-style-type: none"> ① Replace the coupling mouth if it is damaged. ① Replace guide arms and rubber elements if they are damaged. ③ If the coupling mouth has been damaged by jackknifing, the coupling should be dismantled and the horizontal bolt checked. If there are cracks, replace the coupling. When the coupling bolt bends more than 0.5 mm from its intended position, replace the coupling.
	<p>No deformations or cracks are permitted. In the event of damage arising from jackknifing, the horizontal bolt must be carefully examined with respect to bending and any cracks.</p> 	<ol style="list-style-type: none"> ① Replace the coupling mouth if it is damaged. ① Replace guide arms and rubber elements if they are damaged. ③ If the coupling mouth has been damaged by jackknifing, the coupling should be dismantled and the horizontal bolt checked. If there are cracks, replace the coupling. When the coupling bolt bends more than 0.5 mm from its intended position, replace the coupling.

Couplings with V and Dc values

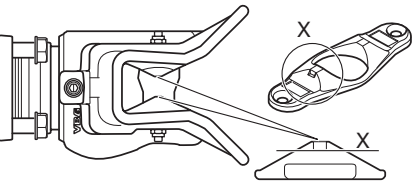
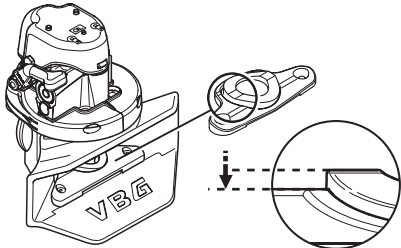
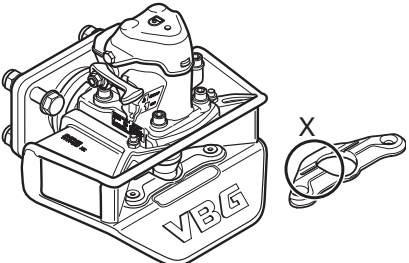
Checkpoint	Symptom	Fault
<p>Coupling mouth.</p> 	<p>Reduced guidance. Noise while driving.</p>	<p>The coupling mouth rattles during driving and the connection manoeuvres may not be secure due to loose or missing bolts in the coupling mouth's bolted joint.</p>
<p>Wear plates.</p> 		<p>The coupling bolt is not triggered during connection because the wear plate is worn and therefore does not lift the coupling bolt high enough. Also check the drawbar eye's wear; see "Guidelines for inspection of drawbars and drawbar eyes".</p>
<p>Wear plates.</p> 	<p>Difficult to connect.</p>	<p>If the wear plate has been loose over time, weariness underneath wear plate cause that screws cannot be tightend.</p>

<p style="text-align: center;">Inspection method</p>	<p style="text-align: center;">Requirements, wear limits, etc.</p>	<p style="text-align: center;">Instructions for rectification</p>
<p>Visually inspect the coupling mouth attachment and wear plate attachment, and whether bolted joints are loose. Torque-tighten bolts to the prescribed torque.</p>	<p>Tightening torque wear plate, 47 Nm. Tightening torque coupling mouth, 90 Nm.</p>	<p style="text-align: center;"> ①②③</p> <p>① In the event of damaged or missing bolts and spacing sleeves, new parts must be fitted.</p>
<p>Visually check the height of the wear plate.</p>  <p>Type VBG 750/795V/795VR</p>  <p>Type VBG 575V/590V</p>  <p>Type VBG 575V-2/575V-3/590VR-2/590VR-3</p>	<p>Minimum height according to marking must be achieved.</p>	<p>① The wear plate's minimum height is indicated = replace wear plate.</p>
<p>Check wear plate underneath.</p>	<p>Tightening torque wear plate, 47 Nm.</p>	<p>① Replace wear plate.</p>

Checkpoint	Symptom	Fault
	<p>The wear marks are incorrectly positioned on the coupling bolt (not centred over the “coupling bolt’s wear surface for the eye”). Quick wear, which leads to play between the vehicle and trailer; constant jolting between the vehicle and trailer may occur.</p>	<p>The trailer jolts an unusual amount behind the traction vehicle due to significant play between the coupling bolt and the drawbar eye. There will be play when the wear plate is excessively worn.</p>
<p>Coupling bolt. The wear from the drawbar eye on the coupling bolt</p> 	<p>The coupling bolt moves up and down slightly when the traction vehicle pushes and pulls at the drawbar. The coupling bolt’s wear/marks from the eye are below the coupling bolt’s biggest diameter. The coupling bolt’s wear/marks from the eye are below and above the coupling bolt’s biggest diameter. Quick wear, which leads to play between the vehicle and trailer; constant jolting between the vehicle and trailer may occur</p>	<p>The coupling bolt’s wear/eye marks are incorrectly positioned on the coupling bolt (not centred over the “coupling bolt’s wear surface for the eye”) due to worn wear plate and/or incorrect drawbar height for coupling.</p>

Inspection method

Visually check the height of the wear plate

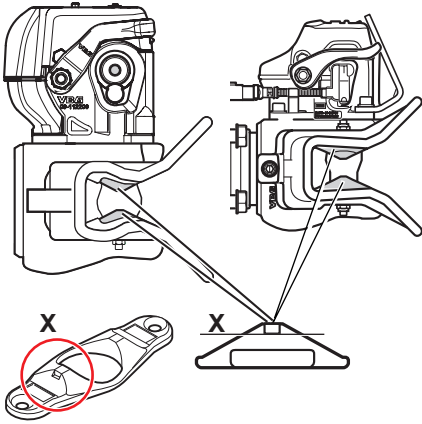

Requirements, wear limits, etc.

Minimum height according to marking must be achieved.



Instructions for rectification

- 1 The wear plate's minimum height is indicated = replace wear plate.

Watch out for any vertical movement of the coupling bolt when the vehicle pushes and pulls at the braked trailer. Check the coupling bolt's wear pattern. Picture 1 with the green field in the middle displays the correct wear amount. Picture 2 with the red field indicates a drawbar eye that is too low due to a worn wear plate. Picture 3 shows a drawbar that is connected at the wrong height relative to the coupling, i.e. wear both above and below the coupling bolt's green field.

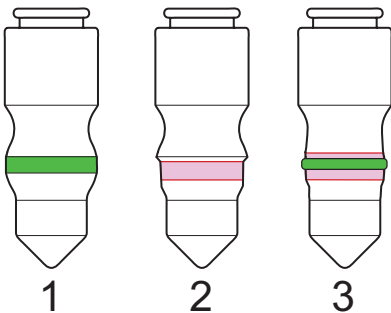

There must be no vertical movement of the coupling bolt when the vehicle is pulling and pushing at the braked trailer. There should be no wear outside of what is indicated in coupling bolt picture 1 or the minimum diameters specified in the table below.

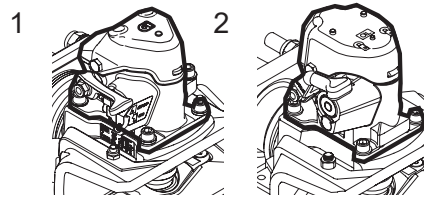

- 1 If the wear on the bolt is too low or the wear plate's minimum height is indicated, it must be replaced. When the wear to the eye for the bolt is too great, the drawbar's balancing force will be reduced; the eye must rest firmly in the coupling mouth.



- 1 If the wear looks the same as for coupling bolt no. 3, the drawbar is at the incorrect height relative to the coupling, in which case its attachments should be rebuilt; the drawbar should be horizontal in the operating position.

- 2 If the bolt is outside of the specified limits in terms of the smallest diameter, the mechanism must be replaced.

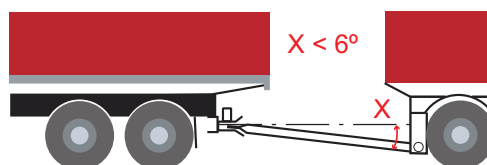
	A (mm)	B (mm)
VBG 750V/795V/795VR	≥42,5	≥55,0
VBG 760	≥44,8	≥55,0
VBG 8500 ² /5190D/5200D	≥38,5	≥47,0
VBG 8500-3 ¹	≥39,5	≥47,0
VBG 8040/4140D	≥28,4	≥36,5
VBG 575V/590VR	≥33,5	≥47,0



The drawbar closure should be less than 6°.

Checkpoint	Symptom	Fault
<p>Coupling jaw and attachment package for articulated drawbars.</p> 	<p>The trailer “winds”, unstable, does not follow the traction vehicle. Difficult to connect. Changed comfort, the trailer jolts.</p>	<p>The trailer “winds” laterally all the time while driving: Low tension in the rubber elements and/or worn rubber elements. Worn rubber element.</p> 

Inspection method

Check that the castellated nut's lock screw is correctly fitted, i.e. in the castellated nut's ports.
 Check-measure the distance between the surrounding bearing boxes.
 Apply trailer brake, push and pull using the traction vehicle. Check the distance between the bearing boxes on loading
 Check the rubber elements' condition.

Requirements, wear limits, etc.

The castellated nut must be locked correctly, see pictures below.

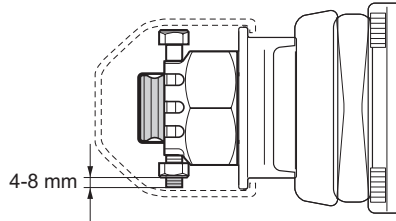
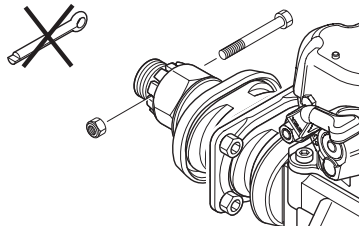

Distance X between bearing boxes a and b, with the correct pre-stress in the rubber elements, must be 16–21 mm. Distance X may vary depending on where the measurement is taken, but must not differ by more than ± 2 mm no matter where the measurement is taken between a and b when the coupling is not loaded; see picture.

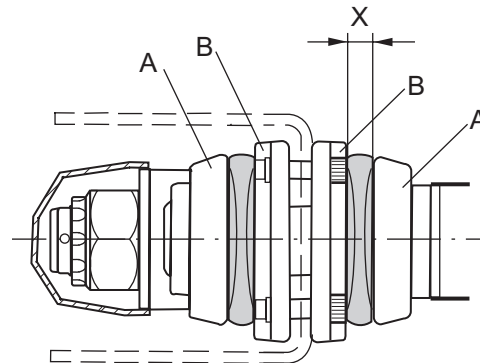

Distance X between the bearing boxes must not exceed X mm when the traction vehicle pushes and pulls heavily (50–80 kN) at the braked trailer.

If the tension is 15 mm, $X \leq 19$ mm with powerful tension by the rear rubber element.

If the tension is 18 mm, $X \leq 25$ mm with powerful tension by the rear rubber element.

If the tension is 21 mm, $X \leq 29$ mm with powerful tension by the rear rubber element.

The rubber elements should not have cracks or other damage.



Instructions for rectification

②

Adjust distance X to the minimum recommended dimension and lock the castellated nut correctly according to instructions. If the lock screw is lying partly outside of the castellated nut's port, a spacer will be placed between the castellated nut and the nut washer. Replace worn rubber elements.

Couplings with only D value

Checkpoint	Symptom	Fault
<p data-bbox="89 271 501 327">Coupling jaw and attachment package for articulated drawbars.</p> 	<p data-bbox="555 264 963 376">The trailer “winds”, unstable, does not follow the traction vehicle. Difficult to connect. Changed comfort, the trailer jolts.</p>	<p data-bbox="1034 271 1453 443">The coupling is not centred, it is tilted down or sideways. The trailer “winds” laterally all the time while driving: Due to bent bearing boxes and/or bent horizontal bolt.</p>

Inspection method

Visual check of the coupling's position without the trailer connected; horizontally, laterally or whether it is rotated.

Requirements, wear limits, etc.

The coupling must point in the direction of travel, not tilt up/down/left/right or be twisted.
The bearing boxes must not be overloaded (bent).
The rubber elements must not have any deformations, cracks, etc.
The horizontal bolt must be straight within 1.0 mm.

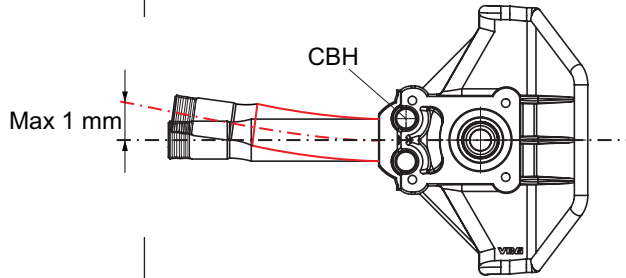

The horizontal bolt must be pressed tightly in and locked using two cylindrical bolts (CBH). The horizontal bolt's thread flanks must not be asymmetrical or damaged; see the picture on the right.





Instructions for rectification

3

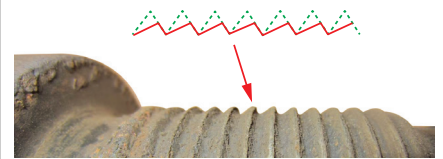
Remove the coupling from the drawbeam if it is not fitted correctly. Bent bearing boxes must be replaced. The horizontal bolt's straightness and attachment to the coupling mouth body must be checked. If the castellated nut has come loose, the horizontal bolt's thread may be worn out and the thread flanks asymmetrical, see below. Replace the coupling jaw if it shows any sign of this damage.

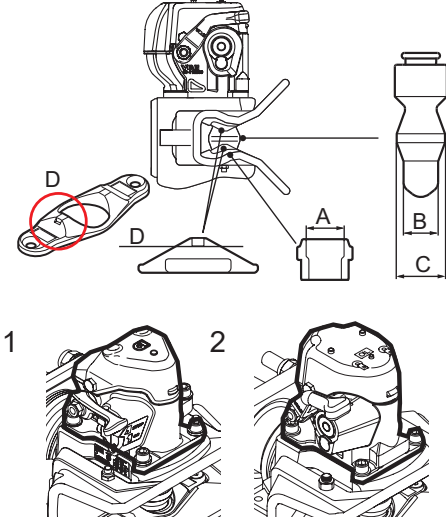

Checkpoint	Symptom	Fault
<p>Bushings in the coupling jaw. Lower/upper jaw bushing.</p>	<p>The rate of wear will increase in the event of significant play between the coupling bolt and bushing. Continuous jolting between vehicle and trailer may occur.</p>	<p>Too much play between coupling bolt and bushings due to worn bushings.</p>
	<p>The coupling does not lock.</p>	<p>The coupling bolt does not move into the locked position during connection because the lower jaw bushing is not completely pressed in or is loose.</p>
<p>Mechanism Manual mechanism.</p> 	<p>The coupling bolt gets stuck in the open position during connection. Not possible to connect.</p>	<p>The mechanism does not close during connection because the coupling bolt jams.</p>
<p>Manual mechanism.</p>	<p>The coupling bolt gets stuck in the open position during connection. Not possible to connect. The handle sometimes jams when engaging the coupling bolt. A scraping noise is sometimes heard. Can sometimes be difficult to engage.</p>	<p>The mechanism does not close during connection. The closing springs are damaged.</p>

Inspection method	Requirements, wear limits, etc.	 Instructions for rectification																																			
<p>Measuring the inside diameters of the lower jaw bushing and interacting surface on the coupling bolt.</p>	<p>Compare the measured diameters with the specified table values.</p>  <table border="1" data-bbox="576 891 1471 1155"> <thead> <tr> <th></th> <th>A (mm)</th> <th>B (mm)</th> <th>C (mm)</th> <th>D (mm)</th> </tr> </thead> <tbody> <tr> <td>VBG 750/795/795VR</td> <td>≤ 45,7</td> <td>≥ 42,5</td> <td>≥ 55,0</td> <td>marking on wear plate</td> </tr> <tr> <td>VBG 760</td> <td>≤ 49,5</td> <td>≥ 44,8</td> <td>≥ 55,0</td> <td></td> </tr> <tr> <td>VBG 8500²/5190D/5200D</td> <td>≤ 41,3</td> <td>≥ 38,5</td> <td>≥ 47,0</td> <td></td> </tr> <tr> <td>VBG 8500-3¹</td> <td>≤ 42,3</td> <td>≥ 39,5</td> <td>≥ 47,0</td> <td></td> </tr> <tr> <td>VBG 8040/4140D</td> <td>≤ 31,5</td> <td>≥ 28,4</td> <td>≥ 36,5</td> <td></td> </tr> <tr> <td>VBG 575V/590VR</td> <td>≤ 36,5</td> <td>≥ 33,5</td> <td>≥ 47,0</td> <td>marking on wear plate</td> </tr> </tbody> </table>		A (mm)	B (mm)	C (mm)	D (mm)	VBG 750/795/795VR	≤ 45,7	≥ 42,5	≥ 55,0	marking on wear plate	VBG 760	≤ 49,5	≥ 44,8	≥ 55,0		VBG 8500 ² /5190D/5200D	≤ 41,3	≥ 38,5	≥ 47,0		VBG 8500-3 ¹	≤ 42,3	≥ 39,5	≥ 47,0		VBG 8040/4140D	≤ 31,5	≥ 28,4	≥ 36,5		VBG 575V/590VR	≤ 36,5	≥ 33,5	≥ 47,0	marking on wear plate	<p>②</p>
	A (mm)	B (mm)	C (mm)	D (mm)																																	
VBG 750/795/795VR	≤ 45,7	≥ 42,5	≥ 55,0	marking on wear plate																																	
VBG 760	≤ 49,5	≥ 44,8	≥ 55,0																																		
VBG 8500 ² /5190D/5200D	≤ 41,3	≥ 38,5	≥ 47,0																																		
VBG 8500-3 ¹	≤ 42,3	≥ 39,5	≥ 47,0																																		
VBG 8040/4140D	≤ 31,5	≥ 28,4	≥ 36,5																																		
VBG 575V/590VR	≤ 36,5	≥ 33,5	≥ 47,0	marking on wear plate																																	
<p>Open and close the coupling. Check the signal pin's position.</p>	<p>The lower jaw bushing must be fully pressed in and must not be loose. The locking pin must assume the locked position.</p>	<p>③ Replace damaged part(s) such as bushing and/or coupling jaw.</p>																																			
<p>Press up the bolt using a mandrel and check that the bolt moves. If the coupling bolt does not fall under its own weight, attempt to close the coupling by pressing the handle down.</p>	<p>It must be easy to move the bolt up slightly and for it to drop back down under its own weight.</p>	<p>③ When the lifting arm releases the coupling bolt, it does not fall down under its own weight. Lubricate the mechanism using "VBG MechOil" through the holes and try again.</p>																																			
<p>Open and close the coupling several times and look out for any symptoms.</p>	<p>None of the examples of symptoms listed should occur.</p>	<p>③ In the event of symptoms, open the mechanism, replace the springs.</p>																																			

Mechanism

Checkpoint	Symptom	Fault
Manual mechanism.	Not possible to connect.	The coupling bolt is not triggered. The wear plate is worn.
Manual mechanism.	Mechanism is loose.	Screw missing.
Manual mechanism.	Mechanism is loose.	The screws are not torque-tighten to the specified torque.

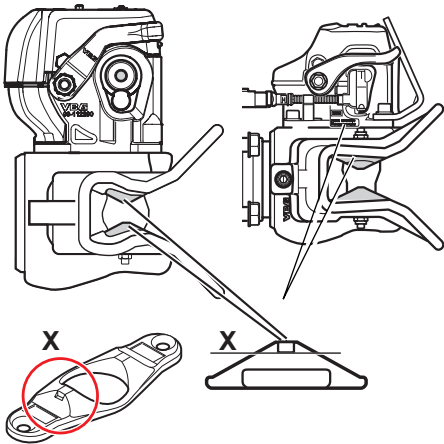
Inspection method	Requirements, wear limits, etc.	 Instructions for rectification ①②③						
<p>In such a case, visually check the height of the wear plate's indication marks.</p>	<p>Minimum height according to marking must be achieved.</p>  <table border="1" data-bbox="579 848 1053 1016"> <thead> <tr> <th></th> <th>X (mm)</th> </tr> </thead> <tbody> <tr> <td>VBG 750/795/795VR</td> <td>marking on wear plate</td> </tr> <tr> <td>VBG 575V-2/590VR-2</td> <td>marking on wear plate</td> </tr> </tbody> </table>		X (mm)	VBG 750/795/795VR	marking on wear plate	VBG 575V-2/590VR-2	marking on wear plate	<p>① The wear plate's minimum height is indicated = replace wear plate(s).</p>
	X (mm)							
VBG 750/795/795VR	marking on wear plate							
VBG 575V-2/590VR-2	marking on wear plate							
<p>Visually check.</p>	<p>Tightening torque 90 Nm.</p>	<p>②</p>						
<p>Replace/torque-tighten screws.</p>	<p>Tightening torque 90 Nm.</p>	<p>③</p>						

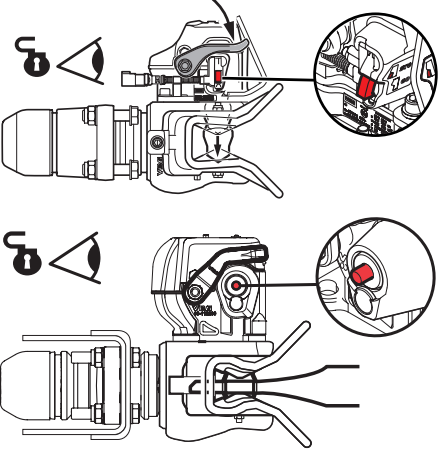
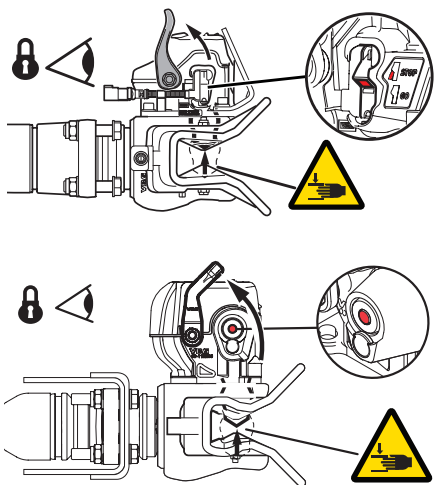
Checkpoint	Symptom	Fault
<p>Signal and locking pin.</p>	<p>The signal pin does not show locked and secured position after this mechanism is triggered and in the locked position. The signal pin is not level with the surface of the plastic cover.</p>	<p>The signal pin does not assume the correct position when the bolt goes down; shows open coupling.</p>  <p>Fault indication for locked mechanism</p>
<p>Signal and locking pin.</p>	<p>The signal pin does not show locked and secured position after this mechanism is triggered and in the locked position. The signal pin is not level with the surface of the plastic cover.</p>	<p>The signal pin does not assume the correct position after the bolt has engaged; shows closed and secured position.</p>  <p>Fault indication for open mechanism</p>

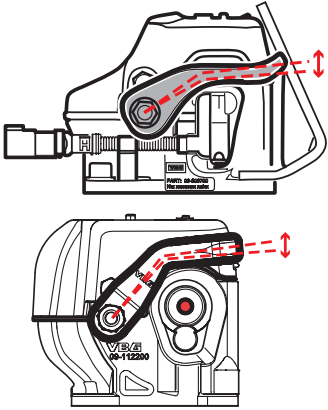
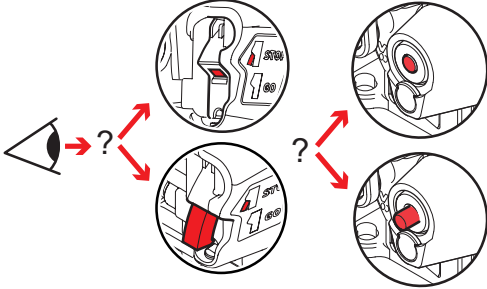
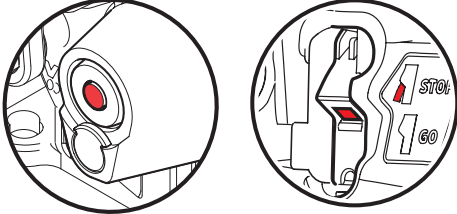
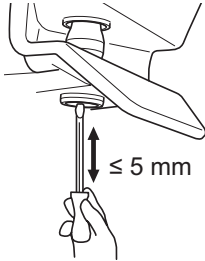
<p style="text-align: center;">Inspection method</p>	<p style="text-align: center;">Requirements, wear limits, etc.</p>	<p style="text-align: center;"> Instructions for rectification</p>
<p>Push the bolt down using the handle; ensure that the handle matches the picture.</p> <p>There must be slight play in the handle before the bolt moves up.</p>  <p>Check the signal pin's position.</p>  <p>Bleed any actuator. Check that there is slight axial play in the coupling bolt using a mandrel. (The closing spring tension must be overcome.)</p>	<p>The signal pin must not be deformed or otherwise put out of order. The coupling bolt, locking pin and signal pin must all slide easily and must not jam.</p> <p>The signal pin must lie level with the surface when the mechanism is closed.</p>  <p>It must be possible to move the coupling bolt up max. 5 mm.</p> 	<p style="text-align: center;">①②③</p> <p style="text-align: center;">③</p> <p>Clean the lower jaw bushing. Lubricate the entire mechanism. Remove the signal and locking pins, clean and lubricate parts. Retest the function. If only the locking pin and the signal pin jam, these must be replaced. If only the signal pin is deformed, replace it. If the signal/locking pin does not work, the mechanism must be replaced.</p>
<p>Close and open the coupling mechanism while watching the signal pin.</p>	<p>The signal pin must move at least 8 mm during closing/opening and must be at least 8 mm away from the plastic cover when the coupling bolt is in raised position.</p>	<p style="text-align: center;">③</p> <p>Remove the signal and locking pins and clean other parts. Fit a new kit containing signal and locking pin, spring and plastic cover.</p>

Air-assisted mechanisms

Checkpoint	Symptom	Fault
AM mechanism.	Intermittently operates when the coupling is closed before the eye actuates the coupling bolt Not possible to connect	The coupling bolt is engaged but sometimes the mechanism triggers without the drawbar eye actuating it due to the bolt being jammed
AM mechanism.	Not possible to connect because the coupling closes when the control valve is switched to closed or when the control kit is disconnected.	The coupling bolt is not engaged.
PA mechanism.	Not possible to connect because the coupling closes when the control valve is switched to closed.	The coupling bolt is not engaged. The coupling will close when the control valve is switched to closed.

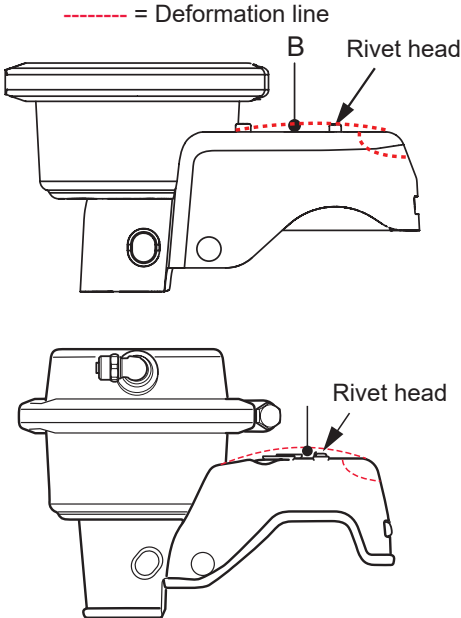
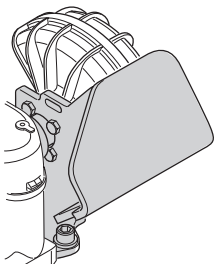
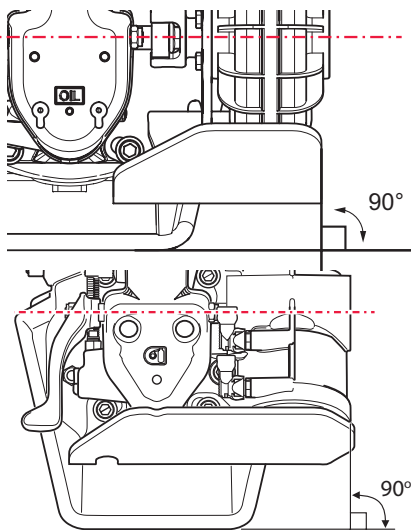
Inspection method	Requirements, wear limits, etc.	 Instructions for rectification
<p>Check the AM unit visually, especially the plate cover.</p> <p>Lubricate the mechanism using thin oil, open the mechanism using air and then bleed.</p> <p>Tap lightly using a hammer in both directions on the mechanism handle.</p>	<p>The must be no dents/deformation deeper/higher than 2 mm from nominal surface B.</p> <p>The rivet head in level B may not be damaged or missing.</p> <p>The coupling must remain open when you tap the handle.</p> 	<p>1 In the event of damage to the AM unit, it must be replaced if the deformation represents a deviation of more than 2 mm or if the rivet is damaged or missing.</p> <p>If the AM unit is undamaged and the coupling still closes when tapped lightly, the mechanism must be replaced.</p>
<p>Try to open using air and to press the handle towards opening and engaging.</p> <p>If the coupling bolt engages, the coupling air pressure and the feed pressure to the control unit must be checked.</p>	<p>The coupling bolt should engage at the minimum pressure of 5.5 bar.</p> <p>The feed pressure should be 5.5 to 8.5 bar.</p>	<p>1 Troubleshoot the vehicle if the air pressure is below 5.5 bar.</p> <p>If the vehicle's air pressure is higher than 5.5 bar and the mechanism engages when the handle is pressed against the opening, the AM unit must be replaced.</p>
<p>Visually check the PA unit's bracket.</p> <p>Look out in particular for deformations and external influences from e.g. reversing.</p> 	<p>The coupling bolt should always stop in the engaged position when the control valve is switched on. The rotary actuator's axle must be in line with the mechanism's output axle.</p> 	<p>1 Replace the bracket if it is damaged.</p> <p>2 Replace damaged actuator.</p>

Checkpoint	Symptom	Fault
PA mechanism.	Not possible to connect because the coupling closes when the control valve is switched to closed.	The coupling bolt is not engaged. The coupling will close when the control valve is switched to closed.
<p>Air-assisted and manual mechanisms</p> <p>PA mechanism and manual mechanism.</p>	<p>Intermittently operates when the coupling is closed before the eye actuates the coupling bolt.</p> <p>Not possible to connect.</p>	<p>The coupling bolt is engaged but sometimes the mechanism triggers without the drawbar eye actuating it due to the bolt being jammed.</p>

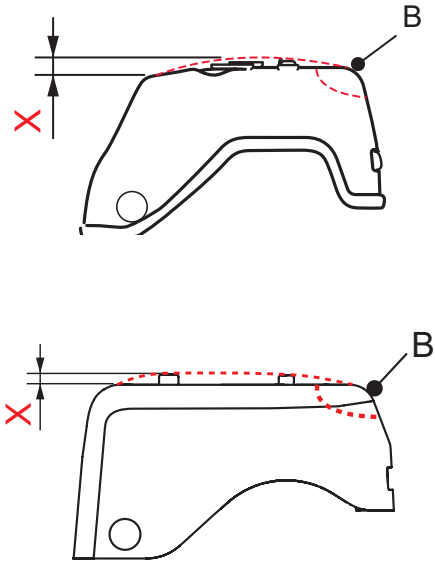
Inspection method	Requirements, wear limits, etc.	 Instructions for rectification
<p>Check the play between the adapter and the rotary actuator's axle. Position the control valve against the opening, then press the mechanism's handle for opening. If the coupling assumes the connected position, the rotary actuator axle and the adaptor are damaged.</p>	<p>The coupling should engage. Max. play between the mechanism's and the rotary actuator's axle $\pm 3^\circ$.</p>	<p>① ② ③</p> <p>① If the handle is pressed against the opening position, the coupling bolt will engage. Replace the adapter and rotary actuator if its axle is damaged/worn.</p>
<p>Check PA unit visually. Lubricate the mechanism using "VBG MechOil" and check that the coupling bolt slides smoothly. Open the mechanism using air and then bleed. Tap lightly using a hammer in both directions on the mechanism handle. Then reconnect the air supply and tap in the same way again.</p>	<p>The coupling bolt must slide easily across the entire lifting height. There must be no dents/deformation deeper/higher than $X=2$ mm from nominal surface B. The coupling should stay open, regardless of whether the air pressure for closing is connected or not.</p> <p>----- = Deformation line</p> 	<p>① If the coupling closes when tapped lightly, the mechanism must be replaced.</p>

Checkpoint	Symptom	Fault
PA adapter.	Does not engage and/or does not close.	Significant play (teeth above).
PA unit.	Audible leakage, abnormal air consumption when the vehicle is stationary.	Internal leakage between the rotary actuator's chambers in extreme cold.
PA connection.	Slow rotating movement with engagement problems, weak opening and closing force.	Opening and/or closing jams due to deformed bracket and/or rotary actuator.
Rotary actuator and bracket.	Play between rotary actuator and bracket.	The rotary actuator rotates very little on opening/closing due to loose bolts.
Bracket/mechanism plan.	Play between rotary actuator bracket and mechanism.	The rotary actuator's bracket moves during opening/closing due to loose bolts.

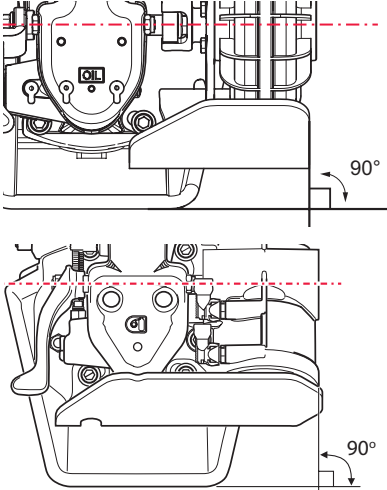
Inspection method	Requirements, wear limits, etc.	 Instructions for rectification
<p>Move the coupling into the open and closed positions several times and observe the coupling bolt's position and compare with the signal pin's position.</p>	<p>The signal pin must always show the locked position after the coupling bolt has been released from the engaged position with full air pressure.</p>	<p>①②③</p> <p>② If the coupling bolt has not engaged or closed correctly each time, the adapter and if necessary the pneumatic actuator must be replaced.</p>
<p>Open the control valve cover and listen for leaks.</p>	<p>No audible air leakage permitted.</p>	<p>① In the event of leakage through the rotary actuator in extremely cold temperatures, the air supply can be cut off by turning the control valve's red handle one quarter turn after the signal pin shows that the coupling is closed/locked.</p>
<p>Visually inspect damage and deformations.</p>	<p>The mechanism's axle must be in line with the rotary actuator's</p> 	<p>① Replace pneumatic actuator and/or bracket.</p>
<p>Move the coupling into the open and closed positions, and check that the rotary actuator does rotate/slide against the bracket.</p>	<p>The rotary actuator must sit firmly against the bracket.</p>	<p>① Tightening torque 25 Nm.</p>
<p>Move the coupling into the open and closed positions, and check that the rotary actuator bracket is sitting firmly against the mechanism.</p>	<p>The rotary actuator bracket must sit firmly against the mechanism.</p>	<p>① Tightening torque 90 Nm.</p>

Control kit for AM coupling

Checkpoint	Symptom	Fault
Parking position for air connection.	Does not close distinctly.	The control unit/parking position does not drain the air from the AM unit.
AM/PA mechanism.	Not possible to connect or disconnect; the mechanism opens slowly or not at all.	The mechanism does not open or opens very slowly due to reduced air flow or low supply pressure.
<p>Specific coupling jaw and coupling model</p>  <p>Nut washer for VBG 795VR/VR-2, VBG 590VR/VR-2.</p>	<p>Cotter bent or cut off. The coupling rotates too easily. Jackknifing damage on endplates, beam, coupling, etc.</p>	<p>The coupling has been overloaded, likely through jackknifing. The VR couplings' nut washer under the castellated nut is bent.</p>

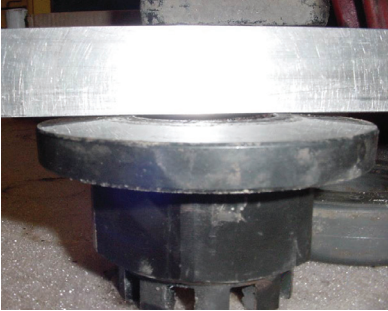
Inspection method	Requirements, wear limits, etc.	 Instructions for rectification ① ② ③
<p>After the air connection is placed in its parking bracket, the coupling bolt is released from the engaged position. Check the closing speed and that the signal pin momentarily assumes the locked position.</p>	<p>The signal pin must show locked and the coupling bolt must quickly assume the locked position</p>	<p>③ If there are symptoms, check that there is free drainage when the air connector is placed in its parking bracket.</p>
<p>Check the condition of the hoses. Check the supply pressure to the control valve and the coupling pressure using a manometer.</p>	<p>There must be no kinks or leaks in the hoses or their connections. The feed pressure should be 5.5 to 8.5 bar.</p>	<p>③ If the vehicle pressure below 5.5 bar, troubleshoot the vehicle. If the pressure is 5.5 bar or higher, the AM/PA unit must be replaced.</p>
<p>Visually check the mounted cotter – if it is in any way not installed correctly or otherwise affected it must be removed and the castellated nut fully loosened. Then check the flatness of the nut washer.</p>  <p>See points for “Couplings with V and Dc values”.</p>	<p>The cotter must be intact and two of the castellated nut’s ports must be in the centre of the cotter hole in the horizontal bolt. The nut washer should be completely flat.</p>	<p>③ Remove the coupling if the cotter is deformed or cut off. If the nut washer is not flat, the coupling must be replaced.</p>



The strong connection

 MEMBER OF VBG GROUP

www.vbg.eu
